

Structure, Stability, and Bonding in Cyclodiphosphazene and Cyclotriphosphazene

Georges Trinquier

Contribution from the Laboratoire de Physique Quantique (C.N.R.S., U.A. 505), Université Paul-Sabatier, 31062 Toulouse Cedex, France. Received April 15, 1985

Abstract: Ab initio calculations using pseudopotentials have been carried out on model cyclophosphazenes $(H_2PN)_2$ and $(H_2PN)_3$. The geometries, optimized at the SCF level, satisfactorily reproduce the experimental data, including the X-ray structure of $((i\text{-Pr}_2\text{N})_2\text{PN})_2$. The cyclodimerization of two H_2PN units results in an energy benefit calculated at 80 kcal/mol, while the cyclotrimerization process brings 210 kcal/mol. The electronic structures of both planar rings are dominated by $-P^+-N^-$ charge alternations (island model). The nitrogen negative charges, being more concentrated in p_x orbitals, create more repulsion in the four-membered ring and induce its pinching. $(H_2PN)_2$ is calculated at 9 kcal/mol less stable than its noncyclic isomer $H_2P=N=N-PH_2$. Substitution of hydrogens by amino groups significantly increases the energy of the H_2PN cyclodimerization. This reaction is quasi-forbidden, thermally, for a direct least-motion concerted pathway (allowed in the excited state). A stepwise pathway, with an open zwitterionic intermediate, should be preferred for the thermal cyclodimerization. Alternative views of the bonding in cyclodiphosphazene are discussed.

I. Introduction

Cyclotriphosphazenes $(R_2PN)_3$ are well-known compounds,¹⁻³ and their electronic structure has been the object of much theoretical investigation, proposing schemes and models to account for the stability of these six-membered rings.^{4,5} The "island" model of Dewar et al.^{4a} is generally considered to satisfactorily describe the bonding in cyclotriphosphazenes.

Such planar rings possess three π -electron pairs, which remain localized on each nitrogen atom, **1**. Of course, d orbitals of phosphorus can mix in this π system, but the six π electrons, commonly associated with the aromatic sextet, remain fundamentally nondelocalized.

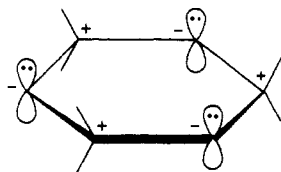

1

It is worth noticing that nobody would have predicted the stability or existence of a four-membered ring cyclodiphosphazene, which bears two π -electron pairs. Even keeping a

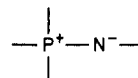

localized arrangement, these two pairs remain associated with an antiaromatic quartet. Therefore, the recent report⁶ of synthesis and structure of a stable cyclodiphosphazene, $((i\text{-Pr}_2\text{N})_2\text{PN})_2$, may have appeared somewhat puzzling. The four-membered ring is prepared by dimerization of the corresponding phosphinonitrene (or phosphonitride) and is shown to be planar with equal P-N bond lengths, **2**.

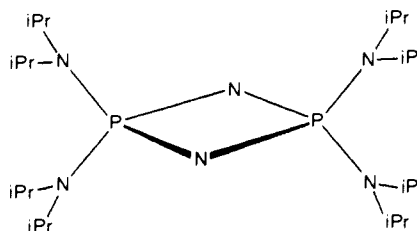

2

(1) Allcock, H. R. "Phosphorus-Nitrogen Compounds"; Academic Press: New York, 1972.

(2) For some recent works on cyclophosphazenes, see: (a) Allen, C. W.; Green, J. C. *Inorg. Chem.* **1980**, *19*, 1719. (b) Allcock, H. R.; Fuller, T. J. *J. Am. Chem. Soc.* **1981**, *103*, 2250. (c) Allcock, H. R.; Harris, P. J.; Nissan, R. A. *J. Am. Chem. Soc.* **1981**, *103*, 2256. (d) Allcock, H. R.; Lavin, K. D.; Riding, G. H.; Suszko, P. R.; Whittle, R. R. *J. Am. Chem. Soc.* **1984**, *106*, 2337. (e) Allcock, H. R.; Lavin, K. D.; Riding, G. H.; Whittle, R. R. *Organometallics* **1984**, *3*, 663. (f) Allcock, H. R.; Suszko, P. R.; Wagner, L. J.; Whittle, R. R.; Boso, B. *J. Am. Chem. Soc.* **1984**, *106*, 4966. (g) Allcock, H. R.; Riding, G. H.; Whittle, R. R. *J. Am. Chem. Soc.* **1984**, *106*, 5561. (h) Allen, C. W.; Bedell, S.; Pennington, W. T.; Cordes, A. W. *Inorg. Chem.* **1985**, *24*, 1653. (i) Allen, C. W.; Bright, R. P. *Inorg. Chim. Acta* **1985**, *99*, 107. (j) Fincham, J. K.; Hursthouse, M. B.; Parkes, H. G.; Shaw, L. S.; Shaw, R. A. *J. Chem. Soc. Chem. Commun.* **1985**, 252. (k) Katti, K. V.; Krishnamurthy, S. S. *J. Chem. Soc., Dalton Trans.* **1985**, 285.

(3) On possible antitumor activity of cyclophosphazenes, see: Labarre, J. F. *Top. Curr. Chem.* **1982**, *102*, 1.

(4) For some theoretical studies on cyclophosphazenes, see: (a) Dewar, M. J. S.; Lucken, E. A. C.; Whitehead, M. A. *J. Chem. Soc.* **1960**, 2423. (b) Craig, D. P.; Paddock, N. L. *J. Chem. Soc.* **1962**, 4118. (c) Craig, D. P.; Mitchell, K. A. R. *J. Chem. Soc.* **1965**, 4682. (d) Mitchell, K. A. R. *Chem. Rev.* **1969**, *69*, 157. (e) Branton, G. R.; Brion, C. E.; Frost, D. C.; Mitchell, K. A. R.; Paddock, N. L. *J. Chem. Soc. A* **1970**, 151. (f) Armstrong, D. R.; Longmuir, G. H.; Perkins, P. G. *J. Chem. Soc., Chem. Commun.* **1972**, 464. (g) Faucher, J. P.; Devanneaux, J.; Leibovici, C.; Labarre, J. F. *J. Mol. Struct.* **1971**, *10*, 439. (h) Faucher, J. P.; Labarre, J. F. *J. Mol. Struct.* **1973**, *17*, 159. (i) Faucher, J. P.; Labarre, J. F. *Phosphorus* **1974**, *3*, 265. (j) Faucher, J. P. Thesis, Université Paul-Sabatier, Toulouse, 1975. (k) Labarre, J. F. *Struct. Bonding* **1978**, *35*, 1. (l) Faucher, J. P.; Labarre, J. F.; Shaw, R. A. *Z. Naturforsch., B* **1976**, *31b*, 677.

The present work is a theoretical study, based on ab initio calculations, of the structure, stability, and bonding of cyclophosphazene and cyclotriphosphazene. Although the former compound is the main object of concern and the latter compound has been the object of previous theoretical works⁴ (mainly at the semiempirical level), we had to include it in the present study in order to compare the structures of the four-membered ring with that of the six-membered ring. Also, it is important to compare the energy of the dimerization of a phosphinonitrene with that of its trimerization. We shall perform the main part of the study on hydrogenated model compounds: H_2PN , $(H_2PN)_2$, and $(H_2PN)_3$. Next, we shall consider substituent effects, performing less complete calculations on amino-substituted molecules which are heavier but closer to real chemical systems.

After a computational detail section, the following points will be examined in this study: structure and bonding in cyclophosphazene and cyclotriphosphazene, energetics of their formation from the phosphinonitrene monomer, structure and energetics of a possible linear isomer of cyclodiphosphazene, namely,

(5) Crasnier, F.; Labarre, J. F. *Top. Curr. Chem.* **1971**, *24*, 33.

(6) Baccaredo, A.; Bertrand, G.; Majoral, J. P.; El Anba, F.; Jaud, J.; Galy, J. *J. Am. Chem. Soc.* **1984**, *106*, 6088.

Table I. SCF-Calculated Equilibrium Geometries (in Å and deg) for Phosphinonitrene, Cyclodiphosphazene, and Cyclotriphosphazene

molecules	parameters	DZ	DZd(P)
(H_2PN) (C_{2v})	P-N	1.624	1.515
	P-H	1.411	1.403
	$\angle\text{HPH}$	110.1	107.4
$(\text{H}_2\text{PN})_2$ (D_{2h})	P-N	1.840	1.650
	P-H	1.420	1.405
	$\angle\text{HPH}$	103.1	101.2
	$\angle\text{NPN}$	93.2	94.2
	$\angle\text{PNP}$	86.8	85.8
$(\text{H}_2\text{PN})_3$ (D_{3h})	P-N	1.724	1.610
	P-H	1.419	1.401
	$\angle\text{NPN}$	120.2	113.5, 116.4 ^a
	$\angle\text{PNP}$	119.8	126.5, 123.6 ^a
	$\angle\text{HPH}$	103.1	101.2

^a Optimized with the DZd(P,N) basis set.

diphosphinodiazene $\text{H}_2\text{P}-\text{N}=\text{N}-\text{PH}_2$, amino substituent effects, and the cyclodimerization reaction.

II. Methods and Basis Sets

The SCF programs that were used throughout this work are based on the HONDO algorithm⁷ modified to include nonempirical pseudopotentials according to the effective core potential technique of Durand and Barthelat.⁸ Two versions are now available. The PSHONDO algorithm⁹ is derived directly from the standard HONDO program. The PSHONDO algorithm¹⁰ is derived from the HONDO version which contains the analytical calculation of the energy gradient components.¹¹ This allows full geometry optimizations and calculations of harmonic force fields. All geometries have been optimized with this gradient technique except for D_{3h} $(\text{H}_2\text{PN})_3$, the four parameters of which have been optimized independently. The convergence threshold for the gradient components is fixed at 0.001.

Four different basis sets were used. The simplest one is a double- ζ (DZ) type for each atom. Adding a d function ($\eta = 0.57$) to phosphorus defines the DZd(P) basis set. Geometry optimizations were performed with these two basis sets. On each DZd(P)-optimized geometry, further calculations were performed with a DZd(P,N) basis set, obtained from the former by adding a d function ($\eta = 0.95$) to nitrogen. Last, we employed a set which includes polarization orbitals on each atom. This basis set, called DZP, is defined by further adding a p function ($\eta = 0.80$) to hydrogen.

The configuration interaction (CI) calculations were performed with the CIPSI method.¹² The subspaces, which are treated variationally in this algorithm, include about 30 determinants in our case. This corresponds to a threshold of ≈ 0.02 for the larger coefficient of the determinant in the first-order perturbed wave function to be treated only perturbatively.

The extended Hückel (EHT) calculations¹³ performed in sections IV and VII used weighted H_{ij} 's and the following parameters: P, $\zeta_{3s} = \zeta_{3p} = 1.60$, $H_{ii}(3s) = -18.6$ eV, $H_{ii}(3p) = -14.0$ eV; N, $\zeta_{2s} = \zeta_{2p} = 1.95$, $H_{ii}(2s) = -26.0$ eV, $H_{ii}(2p) = -13.4$ eV; H, $\zeta_{1s} = 1.30$, $H_{ii}(1s) = -13.6$ eV.

III. Structure of Cyclodiphosphazene and Cyclotriphosphazene

The geometries were optimized under a symmetry constraint. A calculation of the full set of force constants in symmetry coordinates is needed to make certain that the given symmetry does correspond to a real minimum on the potential surface. This was performed for phosphinonitrene and cyclodiphosphazene. In both cases, the calculated vibrational frequencies are real (vide infra), showing that our equilibrium geometries in the chosen symmetries (C_{2v} and D_{2h} , respectively) are true minima on the corresponding surfaces. This checking was not done on cyclotriphosphazene.

Table II. Comparison of P-N Bond Lengths Calculated at the SCF Level with the DZd(P) Basis Set

comps	P-N bond lengths, Å	comps	P-N bond lengths, Å
$\text{P}=\text{N}$	1.47	$(\text{H}_2\text{PN})_3$	1.61
$\text{H}_2\text{P}-\text{N}$	1.52	$(\text{H}_2\text{PN})_2$	1.65
$\text{HP}=\text{NH}$	1.56	$\text{H}_2\text{P}-\text{NH}_2$	1.69
$\text{HP}-\text{NH}_2^+$	1.59	$\text{H}_2\text{P}-\text{NN}-\text{PH}_2$	1.77

but it was not really needed since many of these six-membered rings are structurally known to be basically planar with equal P-N bond lengths.^{14,15}

The optimized geometries are given in Table I. The case of $\text{H}_2\text{P}-\text{N}$ has already been discussed elsewhere¹⁶ and is recalled here only for comparison. Let us first examine the DZd(P) geometries which are the more significant and reliable. The cyclodiphosphazene ring is found to be planar with equal bond lengths. Both the P-N bond length and the pinching of the ring are in good agreement with the experimental structure⁶ of the $(\text{PN})_2$ ring in $((i\text{-Pr}_2\text{N})_2\text{PN})_2$ where P-N = 1.65 Å, $\angle\text{NPN} = 95^\circ$ and $\angle\text{PNP} = 85^\circ$. Even the calculated extracyclic HPH angle in our model (101°) compares well with the observed extracyclic NPN angle in the above-mentioned compound (105°). These findings suggest that the structure of the

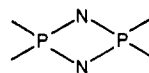

framework is governed by local phenomena which are not closely dependent on exocyclic substituent effects.

The clue to understanding the endocyclic angles lies in the bonding. We shall see that the four-electron π system basically follows the island model, thus inducing a

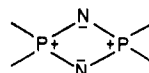

distribution. If the tetrahedral phosphorus centers can transfer part of their positive charge to their substituents, the nitrogen atoms bear their negative charge as a π -electron pair that cannot delocalize. Thereby, the negative charges remain more concentrated on the cycle than do the positive charges. The expected electrostatic repulsion between the nitrogens results in the observed deformation of the ring with an acute angle at the nitrogens and an obtuse angle at the phosphorus. Incidentally, the transannular P...P distance (2.25 Å from our calculations, 2.22 Å from the experimental X-ray data) is as short as the P-P distance in diphosphine, (2.22 Å). However, there is no transannular P...P bonding interaction, as shown by the strongly negative overlap population (vide infra).

In cyclotriphosphazene, we find a P-N distance of 1.61 Å, which is significantly shorter than in cyclodiphosphazene. This value falls within the range of experimentally known P-N bond lengths in cyclotriphosphazenes: $1.55 \approx 1.65$ Å.^{14,15} Unlike the $(\text{H}_2\text{PN})_2$ case, the valence angles of the ring are dependent on the basis set. For most energetic calculations which follow, we use the DZd(P,N) values which indicate that for such six-membered rings, valence angles of 120° are a good geometrical assumption. The planarity of the $(\text{H}_2\text{PN})_2$ and $(\text{H}_2\text{PN})_3$ cycles can be rationalized by both a lesser electrostatic repulsion of the charges of the same signs and a certain π conjugation.

The calculated P-N bond lengths are a good index for evaluating the strength and multiplicity of the bond in various compounds. We have optimized, here and in previous works,¹⁶ the geometries for several systems which possess a P-N bond. The DZd(P) geometry for the lowest (i.e., gauche) conformer of am-

(7) Dupuis, M.; Rys, J.; King, M. F. *J. Chem. Phys.* **1976**, *65*, 383.

(8) Durand, Ph.; Barthelat, J. C. *Theoret. Chim. Acta* **1975**, *38*, 283.

(9) Daudey, J. P., private communication.

(10) Daudey, J. P.; Komiba, N., private communication.

(11) Dupuis, M.; King, H. F. *J. Chem. Phys.* **1978**, *68*, 3998.

(12) Daudey, J. P.; Malrieu, J. P. In "Current Aspects of Quantum Chemistry"; Carbo, T., Ed.; Elsevier: Amsterdam, 1982.

(13) Hoffmann, R. *J. Chem. Phys.* **1963**, *39*, 1397.

(14) Keat, R. In "Organophosphorus Chemistry"; Royal Society of Chemistry: London, 1974; Vol. 6, p 182; 1976, Vol. 7, p 188; 1977, Vol. 8, p 204; 1978, Vol. 9, p 210; 1979, Vol. 10, p 232; 1980, Vol. 11, p 219.

(15) Clardy, J. C.; Kolpa, R. L.; Verkade, J. G. *Phosphorus* **1974**, *4*, 133.

(16) Trinquier, G. *J. Am. Chem. Soc.* **1982**, *104*, 6969.

Table III. Calculated Vibrational Frequencies for Cyclodiphosphazene (H_2PN_2)

symmetry	frequency, cm^{-1}	assignment
b_{1u}	281	PH_2 rocking + nonplanar deformation of the ring
b_{3g}	652	PH_2 twisting
a_g	665	planar deformation of the ring
a_u	775	PH_2 twisting
b_{1g}	798	PH_2 wagging + planar deformation of the ring
b_{1u}	815	PH_2 rocking + nonplanar deformation of the ring
b_{2u}	834	PH_2 wagging + planar deformation of the ring
b_{2g}	849	PH_2 rocking
b_{3u}	929	planar deformation of the ring: PN stretching
a_g	982	planar deformation of the ring: PN stretching
b_{1g}	1032	PH_2 wagging + planar deformation of the ring
b_{2u}	1213	PH_2 wagging
b_{3u}	1306	PH_2 bending (antisym.)
a_g	1350	PH_2 bending (sym.)
b_{2g}	2630	PH stretching (antisym.)
b_{1u}	2636	PH stretching (antisym.)
b_{3u}	2637	PH stretching (sym.)
a_g	2645	PH stretching (sym.)

inophosphine H_2P-NH_2 corresponds to $d(P-N) = 1.69 \text{ \AA}$.^{17,18} This represents a typical value for a single P-N bond length in a free and unhindered system, given our DZd(P) basis set. Among the various calculated bond lengths listed in Table II, the three typical values which correspond to formally triple, double, and single bonds are 1.47, 1.56, and 1.69 \AA , respectively. It is clear from this table that the P-N bonds in the two cyclophosphazenes are half-way between the double bond and the single bond.

As can be seen in Table I, inclusion of d orbitals on phosphorus shortens the bond length in cyclodiphosphazene by as much as 0.19 \AA or 10%. Although the shortening is also significant in H_2PN and $(H_2PN)_3$ (-0.11 \AA), it is less than in the four-membered ring. Even typical bond shortening such as the one occurring in P_4 (-0.18 \AA) corresponds to a more reduced relative variation (-8%).²⁰ We shall see that d orbitals are significantly involved in the localized π systems of the two cyclophosphazenes. The difference between the two compounds comes from the short P-N bond length that is calculated in the six-membered ring with the DZ basis set.

The calculated vibrational frequencies for $(H_2PN)_2$ are given in Table III. Those for H_2PN have been published in a previous work.¹⁶ Keeping in mind that SCF vibrational frequencies are generally overestimated, and that they may be very sensitive to substituents, we have tried to compare our results with the IR data of $((i-Pr_2N)_2PN)_2$.⁶ The IR spectrum of this compound shows four typical bands besides the bands that could be assigned to the extracyclic $i-Pr_2N$ groups using the known spectrum of $(i-Pr_2N)_2P-N_3$. These are located at 745 (large), 840, 985, and 1190 cm^{-1} . They can be assigned to the IR-active vibrations whose frequencies are calculated, applying a correction factor of 0.86, at 701 (b_{1u}), 717 (b_{2u}), 799 (b_{3u}), 1043 (b_{2u}), and 1123 cm^{-1} (b_{3u}), respectively.

(17) The complete results on aminophosphine will be published elsewhere: Trinquier, G.; Daudey, J. P., unpublished results.

(18) For other ab initio calculations on aminophosphine, see: (a) Cowley, A. H.; Mitchell, D. J.; Whangbo, M. H.; Wolfe, S. *J. Am. Chem. Soc.* **1979**, *101*, 5224. (b) Barthelat, M.; Mathis, R.; Mathis, F. *J. Mol. Struct.* **1981**, *85*, 351. (c) Galasso, V. *J. Electron Spectrosc. Rel. Phenom.* **1983**, *32*, 359. (d) Galasso, V. *J. Chem. Phys.* **1984**, *80*, 365. (e) The most refined exploration of the H_2PNH_2 potential surface is in: Gonbeau, D.; Liotard, D.; Pfister-Guillouzo, G. *Nouv. J. Chim.* **1980**, *4*, 228.

(19) Granozzi, G.; Tondello, E.; Zangrande, G.; Daudey, J. P.; Minniti, D. *Organometallics*, in press.

(20) Trinquier, G.; Malrieu, J. P.; Daudey, J. P. *Chem. Phys. Lett.* **1981**, *80*, 552.

Table IV. Calculated Energies for Cyclic Dimerization and Trimerization of Phosphinonitrene H_2P-N

level of theory	ΔE , kcal/mol	
	$2H_2P-N \rightarrow \begin{array}{c} H_2P-N \\ \\ N-PH_2 \end{array}$	$3H_2P-N \rightarrow \begin{array}{c} H_2P-N \\ \quad \\ N-P-N \\ \quad \\ PH_2 \quad H_2 \end{array}$
SCF		
DZ	-32.0	-114.7
DZd(P)	-79.0	216.5
DZd(P,N)	-87.3	211.3
DZp	-86.5	-210.1
CI		
DZd(P)	-62.5	
DZd(P,N)	-79.8	

Table V. Valence Energy Levels (in eV) for $(H_2PN)_2$ and $(H_2PN)_3$ Calculated with the DZP Basis Set

$(H_2PN)_2$			$(H_2PN)_3$		
π^-	b_{3g}	-10.15	π^+	a_2''	-10.35
n_{σ^-}	b_{2u}	-10.20	π	e''	-10.71
π^+	b_{1u}	-10.83	n_{σ}	e'	-10.90
	b_{3u}	-14.05	n_{σ^+}	a_1'	-15.17
n_{σ^+}	a_g	-15.32		e'	-15.75
	b_{1g}	-15.49		e''	-16.00
	b_{2g}	-15.76		a_2''	-17.46
	b_{1u}	-17.59		a_2'	-17.55
	a_g	-20.80		a_1'	-19.99
	b_{3u}	-24.45		e'	-23.95
	b_{2u}	-28.90		e'	-31.02
	a_g	-34.53		a_1'	-33.75

IV. Stability and Bonding

A. Energetics. The calculated energies involved in the cyclodimerization and cyclotrimerization processes are reported in Table IV. There is a significant sensitivity to basis sets and correlation effects. Note the prominent quantitative changes due to the phosphorus d orbitals. Their inclusion in the basis set multiplies, by a factor of 2, the energy gained in the cyclization processes. However, even without inclusion of phosphorus d orbitals in the basis set, the formation of the cyclodimer or cyclotrimer from monomer units is definitely favored. As usual, in main group chemistry, d orbitals are not necessary to account for the existence of compounds and their bonding, but they are required to obtain reliable computed observables.²¹

The formation of the four-membered ring from two phosphinonitrene units provides an energy stabilization calculated at 80 kcal/mol (DZP + CI) which corresponds to ≈ 40 kcal/mol per monomer unit. The formation of the six-membered ring from three phosphinonitrene units provides an energy stabilization calculated at ≈ 210 kcal/mol, which corresponds to ≈ 70 kcal/mol per monomer unit. This value is so large that we did not think it necessary to perform a CI on cyclotriphosphazene. Correcting for zero-point vibration energies, one obtains the enthalpy of the dimerization reaction $\Delta H^\circ \approx -72$ kcal/mol.

The observed formation of $(R_2PN)_2$ from $2R_2P-N$ is rationalized by the calculated exothermicity of the model reaction $2H_2PN \rightarrow (H_2PN)_2$. However, one must admit that the trimerization reaction should be even more thermodynamically favored. A kinetic explanation must be sought, therefore, to account for the formation of the four-membered ring in the operating conditions of ref 6. An entropy factor could possibly play the important part in preventing the reaction from going beyond the cyclodimerization.

B. Electronic Structure. Valence energy levels for $(H_2PN)_2$ and $(H_2PN)_3$ are given in Table V. The nature of the MO's in both compounds is analogous. The inner MO's correspond to the P-N and P-H bonds. The highest MO's correspond to lone pairs which are localized on nitrogen. They divide into two sets: a set

(21) Kutzelnigg, W. *Angew. Chem., Int. Ed. Engl.* **1984**, *23*, 272.

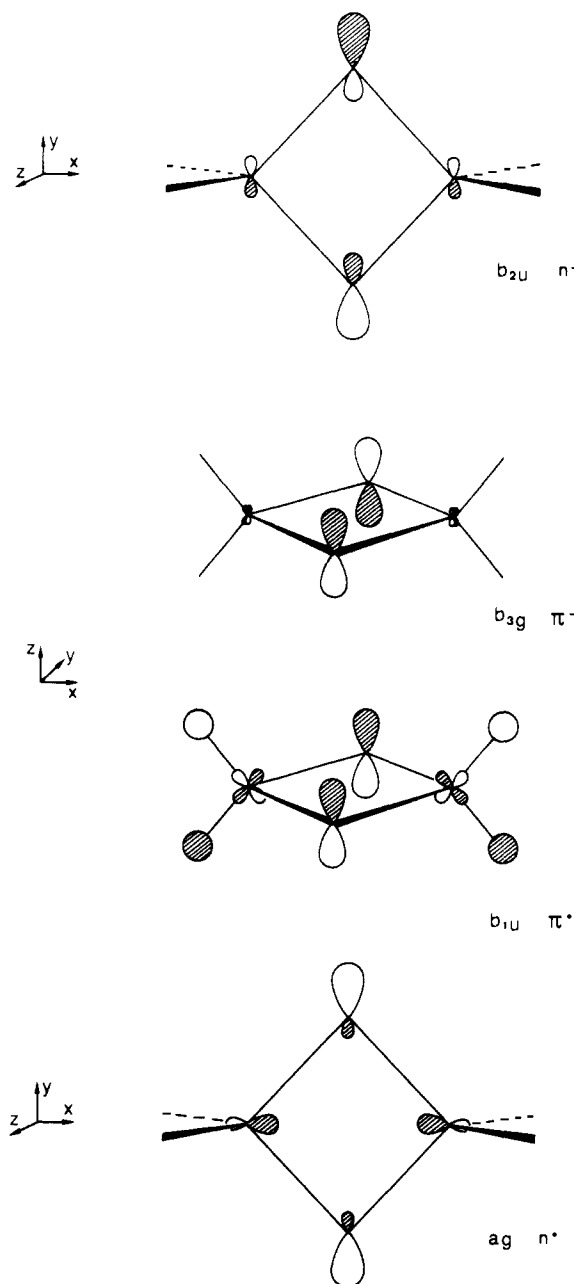

Figure 1. Highest occupied orbitals corresponding to nitrogen lone pairs in cyclodiphosphazene.

of n_p lone pairs formed by sp^2 hybrids pointing away from the cycle and a set of pure p lone pairs forming the π system which remains nondelocalized. This peculiar localized π system features the island model. For the four-membered ring $(H_2PN)_2$, we give, in Figure 1, the shape of these four occupied orbitals (in the DZd(P) ordering which differs slightly from the DZP ordering of Table V). The nonconjugation of these π systems appears already from the small splittings of the π levels. In both compounds, these are remarkably close to one another (-10.2 to -10.8 eV; see Table V). In comparison, the occupied π levels of benzene jump from -8.8 to -12.8 eV as calculated in similar conditions.²² Note that the in-phase combination of these nitrogen p orbitals, noted as π^+ , is the lower level in $(H_2PN)_2$, while it is the higher level in $(H_2PN)_3$. The d_{xz} orbitals of phosphorus are very much involved in these π^+ orbitals (see Figure 1). The corresponding coefficient of each phosphorus d_{xz} orbital in the wave function is as large as 0.14 in the b_{1u} MO of $(H_2PN)_2$, while only 0.10 in the a_2'' MO of $(H_2PN)_3$. This may be the key for understanding why π^+ is lower in the four-membered ring. The transannular

Table VI. Calculated Ionization Potentials (in eV) for $(H_2PN)_2$ (DZP Basis Set)

n_σ^-	b_{2u}	8.6	n_σ^+	a_g	13.9
π^-	b_{3g}	8.8		b_{1g}	14.3
π^+	b_{1u}	10.3		b_{2g}	15.6
	b_{3u}	13.4			

Table VII. Results from Mulliken Population Analyses (DZd(P) Basis Set)

	net atomic charges			population of N p_z orbitals	population of P d orbitals
	P	N	H		
H_2PN	+0.00	-0.18	+0.09	0.67	0.25
$(H_2PN)_2$	+0.33	-0.47	+0.07	1.66	0.41
$(H_2PN)_3$	+0.40	-0.54	+0.07	1.67	0.42

Table VIII. P-N Overlap Populations (DZd(P) Basis Set)

molecules	total	π
H_2P-NH_2 (gauche)	0.64	
HP=NH	1.01	0.47
H_2P-N	0.88	0.43
$(H_2P-N)_2$	0.60	0.16
$(H_2P-N)_3$	0.92	0.18
$\left. \begin{array}{l} H_2P-N \\ \\ N-P(NH_2)_2 \end{array} \right\} \begin{array}{l} \text{endocyclic} \\ \text{exocyclic} \end{array}$	0.71	0.20
	0.74	

P...P distance being short in the cyclodimer (2.25 Å), a weak but significant overlap may occur between the two d_{xz} orbitals in the b_{1u} π^+ MO. Actually the total overlap population between the two d_{xz} orbitals on phosphorus is +0.004 in $(H_2PN)_2$, while 0.000 in $(H_2PN)_3$. Moreover, when calculated with the DZ basis set without d orbitals on phosphorus, the π^+ and π^- levels have close values (-10.2 eV for the dimer and a similar ordering for the trimer ($\pi^+ = -10.4$ eV; $\pi^- = -9.9$ eV)). It can also be pointed out that an extended Hückel calculation performed on the DZd(P) geometries, and not including 3d orbitals in the phosphorus parameters, also gives π^+ higher than π^- for both compounds. Finally, the highest ionization potentials of cyclodiphosphazene have been calculated according to a first-order perturbative treatment of repolarization and pair correlation effects.^{16,19} They are listed in Table VI. Note the n_σ^-/π^- inversion with respect to Koopman's ordering.

Cyclodiphosphazenes therefore can be conceptualized as a sequence of amidure-phosphonium units, 3, in which the negative charge of nitrogen is carried by a pure p lone pair perpendicular

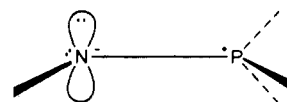

3

to the mean plane of the ring. An alternative view of this framework is a dative (or semipolar) bond between a phosphine and a singlet nitrene, 4. These pictures imply that the electronic

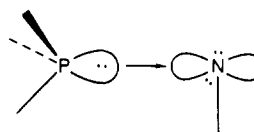

4

population in the nitrogen $2p_z$ orbital should be close to 2 and that the net atomic charge on the nitrogen atom should be large. Formally, the latter is equal to -1 , but in fact reduced due to σ polarization and to a certain amount of conjugation with phos-

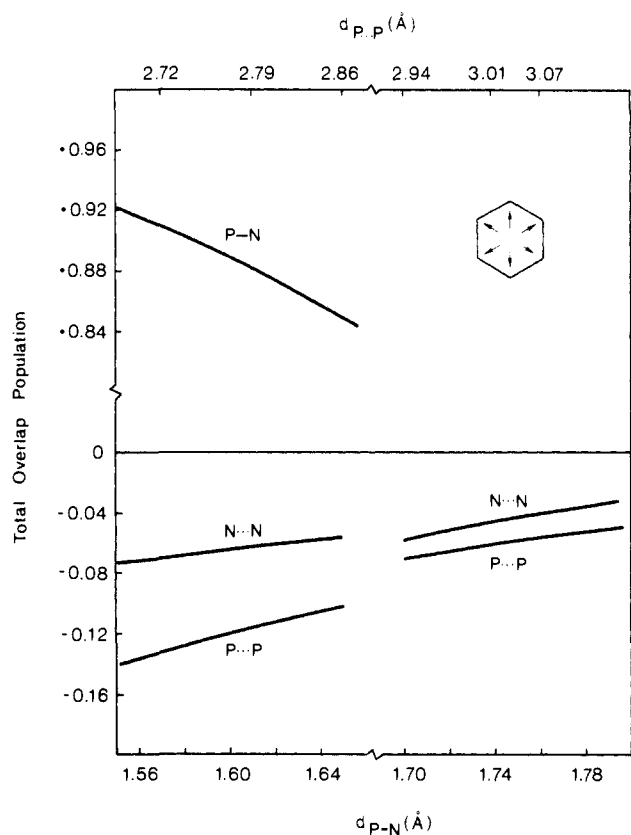
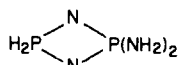

Figure 2. Variation of total overlap populations with the breathing deformation of the ring in cyclotriphosphazene. Right, DZ basis set; left, DZd(P) basis set.

phorus d orbitals. Results from Mulliken population analyses, given in Table VII, show both the excess of electrons on nitrogen and the significant population of phosphorus d orbitals. On the other hand, Table VIII makes clear that π contributions to the endocyclic P-N bonding (i.e., $p_{\pi}(\text{N})-d_{\pi}(\text{P})$ contributions) remain weak.

A point which has been raised several times is the existence of transannular interactions, or intraring bonding, in cyclic phosphazenes. Some authors have found significant intraring P...P bond orders in cyclic phosphazenes on the basis of calculated bond orders, electron densities,^{4f} Wiberg indexes, and energy decomposition in mono- and bicentric terms.^{4g-1} On the basis of our calculated total overlap populations, the existence of transannular P...P interactions in cyclodiphosphazene and cyclotriphosphazene is not confirmed. For the equilibrium structures, these overlap populations are calculated at -0.2 to -0.4 in $(\text{H}_2\text{PN})_2$ (depending on the basis set) and at -0.1 in $(\text{H}_2\text{PN})_3$. EHT calculations also give negative values. To try to avoid ambiguity, we have plotted, in Figure 2, the variations of the relevant overlap populations in cyclotriphosphazene when the distances are varied with the breathing of the ring, keeping valence angles in the ring fixed at 120° . It can be seen that the shorter the intra-ring P...P distance, the more antibonding the interaction. This holds for the N...N interaction as well, whatever the basis set. In $(\text{R}_2\text{PN})_2$ where the experimental P...P distance is as short as 2.22 \AA , the negative P...P overlap population is not reduced by exocyclic substitutions: -0.34 in



vs. -0.26 in $(\text{H}_2\text{PN})_2$, at the DZd(P) level.

V. Noncyclic Dimer $\text{H}_2\text{P}-\text{N}=\text{N}-\text{PH}_2$

An alternative to cyclodimerization of H_2PN is its dimerization into a noncyclic diazene $\text{H}_2\text{P}-\text{N}=\text{N}-\text{PH}_2$, obtained by coupling two nitrogen ends. We have investigated this linear isomer and attempted to locate its energy with respect to the cyclodimer. Given a trans configuration for the $-\text{N}=\text{N}-$ double bond, two

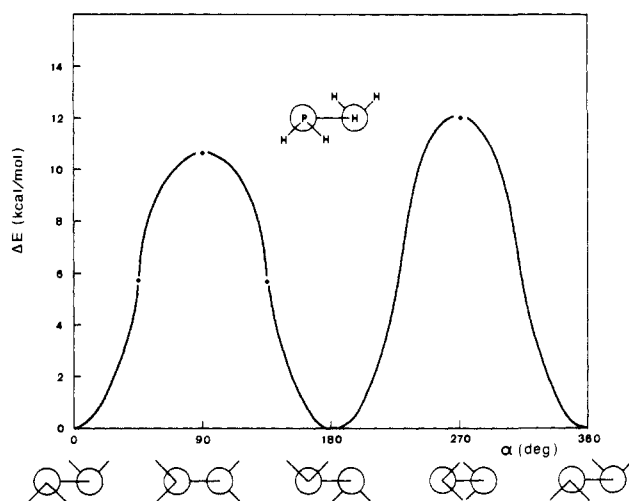
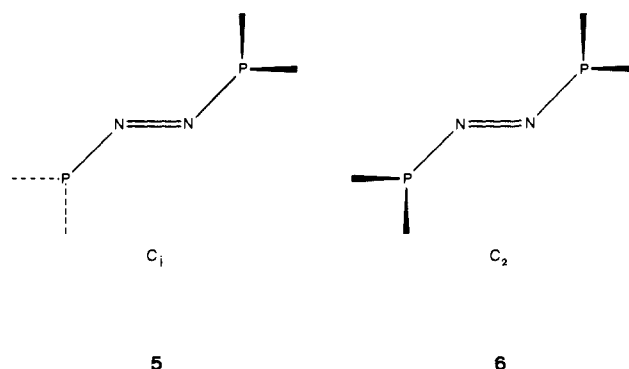

Figure 3. Energy variation with the rotation of the phosphino groups in C_1 *trans*- $\text{H}_2\text{P}-\text{N}=\text{N}-\text{PH}_2$.

forms are possible according to the relative positions of the pyramidalized phosphino groups: *trans*, **5**, and *cis*, **6**.



In a preliminary calculation, performed with guess geometrical parameters, the *trans* form was found to be more stable than the *cis* form by 3 kcal/mol. On the C_1 *trans* form, we next checked if the actual preferred conformation of the phosphino groups was allowing the conjugation of the phosphino lone pairs with the $-\text{N}=\text{N}-\pi$ bond, as in **5**. For this, we plotted the energy variation when the phosphino groups are rotated around the N-P bonds.²³ The energy curve (Figure 3) shows that the conformation preserving the conjugation is favored. Note that the 270° conformation, in which the phosphino and imino lone pairs are eclipsed, is higher in energy than the 90° conformation in which these two lone pairs are in the anti position. Finally, the *trans* form (with $\alpha = 0$) was fully optimized, leading to the geometry given in Figure 4. The $-\text{N}=\text{N}-$ framework basically preserves its *trans*-diazene (or *trans*-diimide) geometry (NN = 1.242 \AA , HNN = 111° calculated with a DZ basis set²⁴). The PH_2 groups should induce a limited conjugation, in fact, since they remain strongly pyramidalized and display long PN bonds. Actually, these P-N bonds are longer than in *cis*- and *trans*- $\text{H}_2\text{P}-\text{NH}_2$, and they are not unlike the large bond length calculated in the somewhat similar triplet phosphonitrene system $\text{H}_2\text{P}-\text{N}$ ($d_{\text{PN}} = 1.81 \text{ \AA}$ at a Nesbet level¹⁶ and 1.78 \AA at a UHF level²⁶).

A planar form of $\text{H}_2\text{P}-\text{N}=\text{N}-\text{PH}_2$, which is the transition state for inversion of both phosphino groups, was calculated to lie at 81 kcal/mol above the *trans* form (DZd(P) level). This state corresponds to the following parameters: NN = 1.253 \AA , PN = 1.696 \AA , PH = 1.390 \AA , PNN = 119.5° , HPH = 125.4° , HPN

(23) The mean geometry used in this exploration corresponds to NN = 1.241 \AA , PN = 1.72 \AA , PH = 1.414 \AA , HPH = HPN = 98° , PNN = 118.6° .

(24) Parsons, C. A.; Dykstra, C. E. *J. Chem. Phys.* **1979**, *71*, 3025.

(25) Frost, D. C.; Lau, W. M.; McDowell, C. A.; Westwood, N. P. C. *J. Mol. Struct. Theochem.* **1982**, *86*, 283.

(26) Trinquier, G., unpublished results.

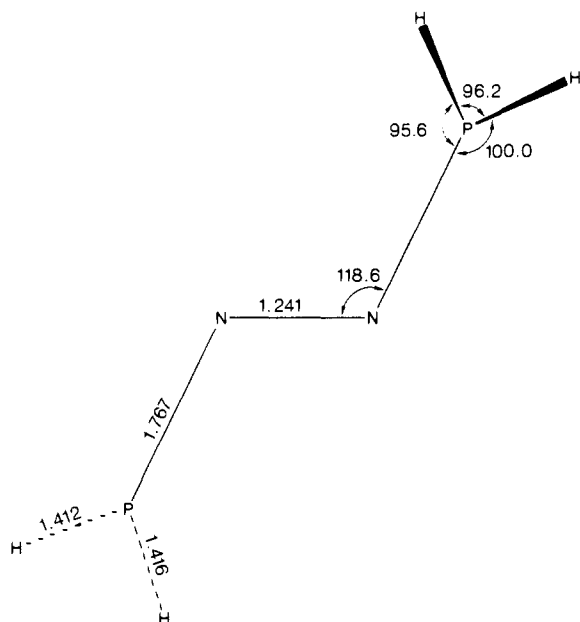

Figure 4. C_1 -optimized geometry of *trans*- $H_2P-N=N-PH_2$, in angstroms and degrees.

Table IX. Calculated Highest Ionization Potentials for C_1 *trans*- $H_2P-N=N-PH_2$ (in eV) (DZP Basis Set)

		Koopman	cor
$6a_g$	n_N^+	9.5	8.4
$6a_u$	n_p^-	10.0	9.8
$5a_g$	n_p^+	11.4	11.2
$5a_u$		14.1	13.9
$4a_g$		14.5	14.4
$4a_u$	π_{NN}	15.1	15.1 ^a
$3a_g$		17.1	16.0
$3a_u$	n_N^-	17.1	16.0

^aKT value is kept for this genuine π orbital.

Table X. Relative Energies of $H_2P-N=N-PH_2$ (in kcal/mol)

		$\Delta E[(H_2PN)_2 \rightarrow H_2PNNPH_2]$	$\Delta E(2H_2PN \rightarrow H_2PNNPH_2)$
SCF	DZd(P)	-8.3	-87.3
	DZd(P,N)	-10.5	-97.8
	DZP	-10.4	-96.9
IC	DZd(P,N)	-8.9	-88.7

= 118.1°, and 116.5° (cis and trans with respect to NN, respectively). Note that in this constrained planar conjugated form, the PN bond takes up a typical single bond length value, i.e., shorter than in the relaxed form.

With its four lone pairs and its NN π bond, such a system is worth study for its ionization potentials. For the stable trans form, these are given in Table IX, as calculated with Koopman's theorem (KT) approximation and after corrections. The extent of conjugation brought by the phosphino groups can be inferred by comparing the calculated π_{NN} level in $H_2P-N=N-PH_2$ (-15.1 eV) with the one calculated in *trans*-diazene $HN=NH$ (-14.0 eV, 4-31 G).²⁵

The relative energies of $H_2P-N=N-PH_2$ with respect to its cyclic isomer and with respect to two H_2P-N monomer units are listed in Table X. The linear isomer is found to be 9 kcal/mol more stable than the cyclic isomer.

The coplanar end-to-end dimerization of H_2P-N into the *trans*-diazene product exhibits a level crossing, 7. If the reaction occurs under C_2 symmetry, leading to cis-pyramidalized phosphino groups, 6, the level crossing is real since π^{*+} is of symmetry a while n_σ^- is of symmetry b . If the reaction occurs under C_1 symmetry, leading to trans-pyramidalized phosphino groups, 5, the level crossing is formally avoided since both π^{*+} and n_σ^- are of a_u symmetry. However, due to their nature, these two orbitals

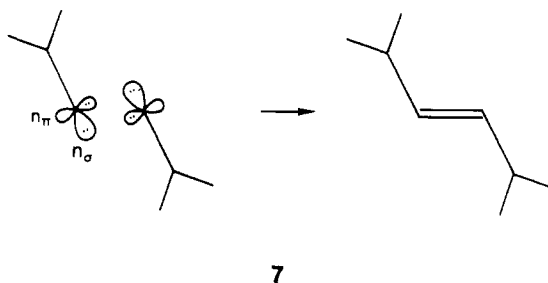
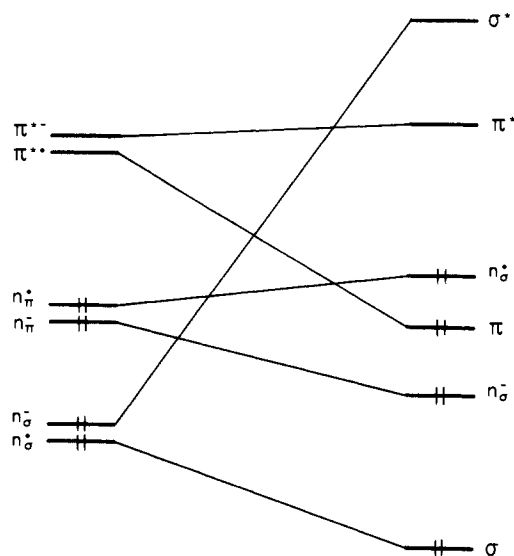

should interact very little and a large barrier can be expected in this approach also.

In a noncoplanar approach like 8, the $n_\sigma-\pi^*$ interactions are optimized, but the repulsions of the n_π pairs (not shown in 8) are unfavorable. By hybridizing the n_π lone pairs into sp^2 , we define

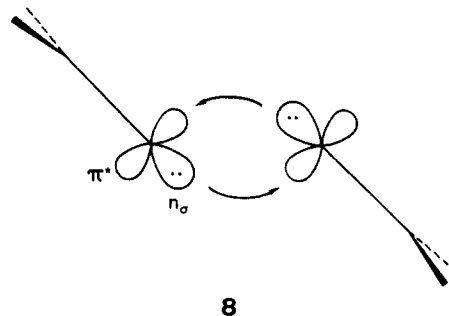

a non-least-motion pathway in which all the starting repulsions are reduced to their best, 9. This pathway can be expected to have a reduced barrier, if any. However, it requires precise and

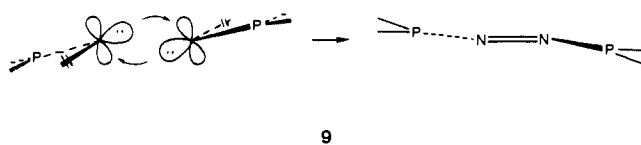

synchronized movements of the two monomer units, which can be in competition with another dimerization process such as a single $P \rightarrow N$ coupling between two R_2PN units.

VI. Exocyclic Amino Substitution

We have investigated, at the SCF DZd(P) level, the 1,1-diamino derivative 10 which results from the substitution of two hydrogens by two amino groups in $(H_2PN)_2$. Keeping the optimized geometry of the cyclic framework, fixing the exocyclic PN bonds at 1.650 Å (i.e., equal to the endocyclic PN bonds, as in 2), and assuming planar amino groups ($NH = 1.010$ Å, $HNH = PNH$

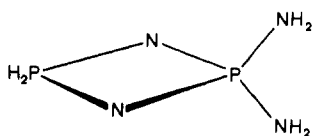

10

($\approx 120^\circ$), we first examined the conrotatory rotation of the amino groups, **11**, to assess their preferred conformation. In Figure 5

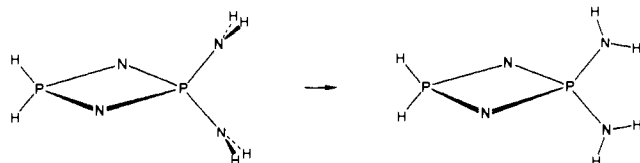

a

b

11

are plotted the energy variation and PN overlap population variations. The energy minimum occurs for a twisting angle of $\theta \approx 60^\circ$. In **2**, the observed corresponding angle is $\theta \approx 30^\circ$. Steric constraints due to isopropyl groups should govern the conformation in **2**. These constraints do not exist in the model **10** in which the two amino groups do not hinder each other. Note that **11b**, in which two hydrogens are only 2.22 Å apart, is calculated at 8 kcal/mol more stable than **11a** (Figure 5).

A Walsh diagram for the highest occupied orbitals is given in Figure 6. The amino lone pair repulsion is minimized in **11b**. Considering the whole interaction between the four nitrogen π lone pairs, the two endocyclic π pairs (noted π_{en}) and the two exocyclic π amino pairs (noted π_{ex}), a determination of which of the two extreme conformations in **11** minimizes the electronic repulsions is not straightforward. In **11a**, the two amino lone pairs interact more with each other but less with the cycle lone pairs. Only their out-of-phase combination π_{ex}^- mixes significantly with the in-phase combination of the cycle π orbitals π_{en}^+ , giving the 7b and 8b orbitals **12** in the left part of Figure 6.



7b

8b

12

In **11b**, the two amino lone pairs interact less with each other. Their out-of-phase combination π_{ex}^- now mixes significantly with the out-of-phase combination of the cycle π orbitals π_{en}^- , giving the 8a and 9a orbitals **13** in the right part of Figure 6. Note,

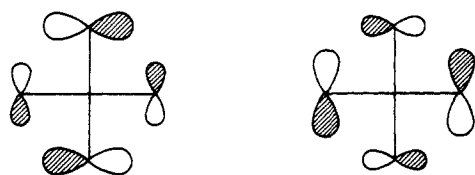

8a

9a

13

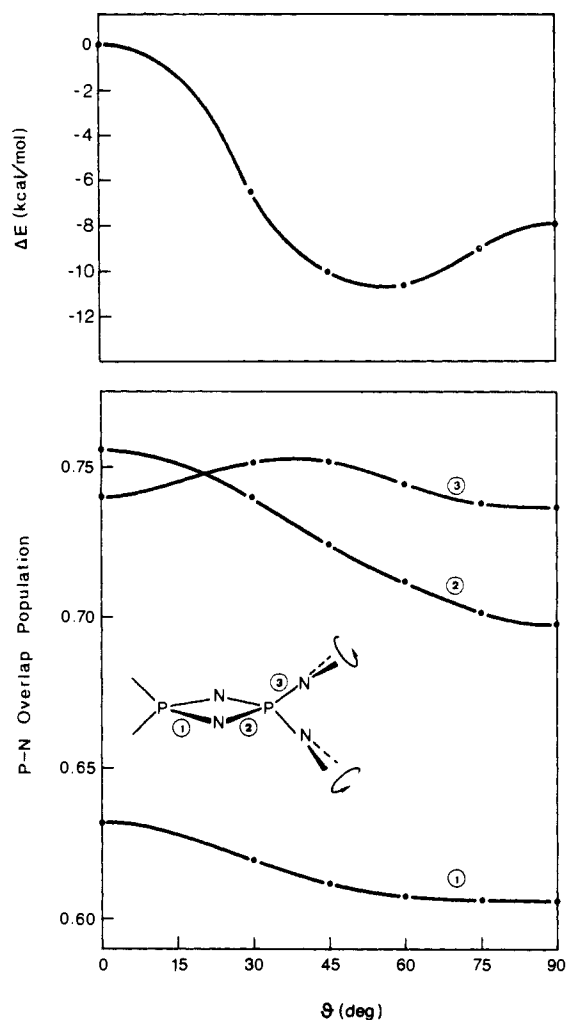
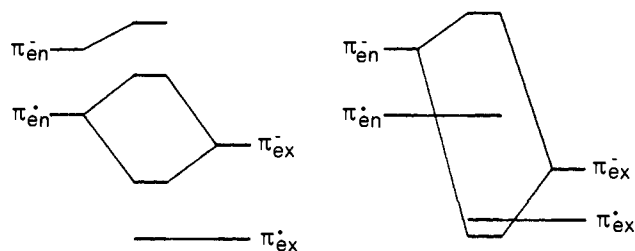

Figure 5. Energy (top) and P-N total overlap population (bottom) variations with the conrotatory rotation of the amino groups in 1,1-diaminocyclophosphazene.

in Figure 6, that π_{ex}^+ (8a, left; 7b right) is not much changed during the rotation and that π_{en}^+ in **11b** (right side) has about the same value as π^+ in $(H_2PN)_2$. Finally, all interactions between nitrogen π lone pairs can be schematized as in **14**. It should also



14

be mentioned that **6b** is largely stabilized (by ≈ 1 eV) from **11a** to **11b** due to a mixing of π_{ex}^+ in a cycle bonding orbital, **15a**. To summarize this conformational study, the amino groups are preferable in a coplanar position as in **11b**, but the size of the

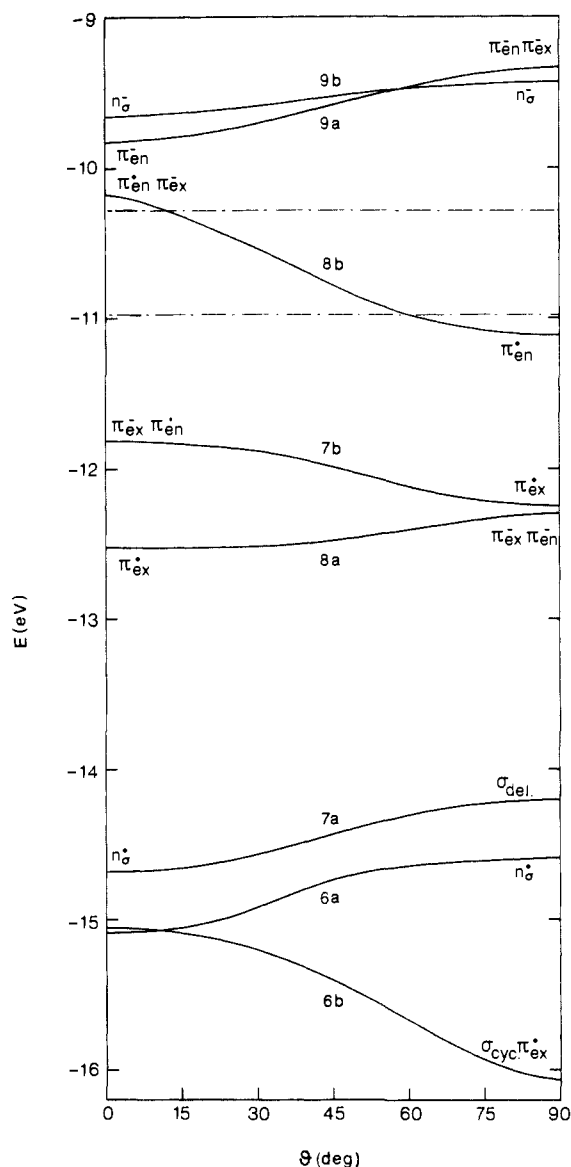
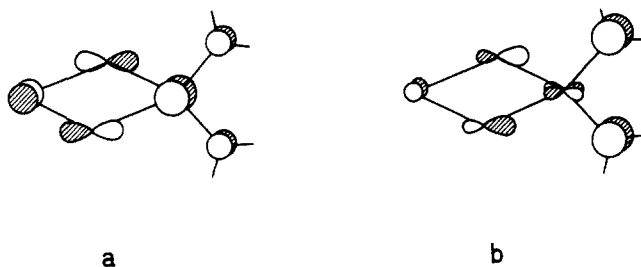

Figure 6. Evolution of the highest occupied energy levels during the conrotatory rotation of the amino groups in 1,1-diaminocyclodiphosphazene. The dashed lines indicate the π^+ (lower) and π^- (higher) levels calculated in unsubstituted $(\text{H}_2\text{PN})_2$.

substituents carried on the amino groups may induce large deviations from this conformation.



15

By applying our corrections to the Koopman's values of Figure 6, we obtain the ionization potentials given in Figure 7. Three inversions occur on the right side of the diagram: n_σ^-/π_{en}^- , π_{ex}^-/π_{ex}^+ , and $n_\sigma^+/\sigma_{cycle}$.

The amino substitution has not allowed a delocalization of the positive charge on phosphorus by π conjugation. The net atomic charge on the phosphorus atom which bears the amino groups

varies from +0.39 to +0.48 along the rotation **11**, while the opposite phosphorus atom varies from +0.33 to +0.29. The corresponding net charge in the unsubstituted molecule $(\text{H}_2\text{PN})_2$ is +0.33. Amino groups have therefore played their acceptor inductive part but have not brought much mesomeric conjugation. The latter is only present under a certain amount of $p_\pi-d_\pi$ conjugation such as the one occurring typically in π_{ex}^+ (7b) of **11a** (see **15b**). Such mixing is responsible for the larger d population on the phosphorus atom carrying the two amino groups (0.56 vs. 0.40 for the opposite unsubstituted phosphorus). Figure 5 and Table VIII show that the endocyclic PN overlap population has been enhanced by the amino substitution. Note that both endocyclic and exocyclic PN bonds starting from the same phosphorus atom have close overlap populations.

To have an energetic indication of the stabilization of the cyclodiphosphazene by amino substituents, we have calculated the energy of reaction 1. The geometry of $(\text{H}_2\text{N})_2\text{PN}$ is chosen

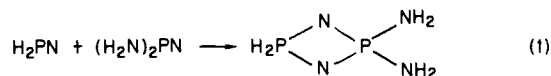

as derived from the optimized geometry of H_2PN : $\text{P}=\text{N} = 1.515 \text{ \AA}$, $\angle\text{NPN} = 107.4^\circ$, $\text{P}-\text{N} = 1.650 \text{ \AA}$, $\text{NH} = 1.010 \text{ \AA}$, $\angle\text{HNP} = \angle\text{HNP} = 120^\circ$. As expected the conrotatory rotation of the amino groups from a planar geometry, related to **11b**, to a perpendicular geometry, related to **11a**, corresponds to a monotonic 10 kcal/mol increase of total energy. The stable planar form is more conjugated and corresponds to a lesser repulsion of the amino lone pairs.

The energy of reaction 1 is calculated at -96.0 kcal/mol which is to be compared to the -79.0 kcal/mol for the cyclodimerization of unsubstituted H_2PN . One can extrapolate to $\sim 100\text{--}110 \text{ kcal/mol}$ for the reaction energy in the cyclodimerization of two $(\text{H}_2\text{N})_2\text{PN}$ into $((\text{H}_2\text{N})_2\text{PN})_2$. Although the geometries of our diaminated models have not been fully optimized, it can be deduced from these calculations that exocyclic amino groups significantly enhance the exothermicity of the cyclodimerization.

VII. Cyclodimerization Reaction

The orbital correlation diagram for the least-motion head-to-tail dimerization of H_2PN , given in Figure 8, is not basically different from that of the ethylene dimerization into cyclobutane. It exhibits a level crossing between the relevant π orbitals which undergo the main changes in the reaction. Although the level crossing is here formally avoided²⁷ when the thermal reaction takes place under C_{2h} , C_2 , or C_i symmetry (since π_- and π_+ in Figure 8 are both of b_u , b , or a_u symmetry, respectively), an important energy barrier can be expected for this unfavorable pathway. We have computed a C_{2h} least-motion coupling in which bond lengths and bond angles are varied regularly.²⁸ The calculated energy curve corresponding to this least-motion pathway (Figure 9) exhibits a large barrier of more than 45 kcal/mol. The Walsh diagrams for this reaction have been plotted from both SCF and EHT results (in the latter, the virtual orbitals are better described). They show clearly the b_u - b_u avoided crossing which occurs, like the energy barrier, between the sixth and seventh step of our defined reaction pathway. It is clear that such a least-motion path is very unfavorable, even if basis set extension and CI inclusion would significantly lower the energy barrier of Figure 9 (the CI would enhance the b_u - b_u mixing), and even if more favorable concerted pathways can be found.²⁹

(27) This is not the case in the D_{2h} thermal cyclodimerization of ethylene where the two relevant orbitals are of different symmetry: b_{2u} and b_{3u} .

(28) At the starting point of our reaction, the two H_2PN units, in their optimized geometries, are facing each other 4 Å apart, thus defining a NPNP rectangle 4 Å long and 1.515 Å wide. Ten regular variations of bond lengths and bond angles are then considered, which lead to the optimized geometry of $(\text{H}_2\text{PN})_2$.

(29) A simple distortion of our rectangular starting system into a parallelogram in which the two phosphorus atoms are farther from one another could define a better starting point for our C_{2h} reaction pathway.

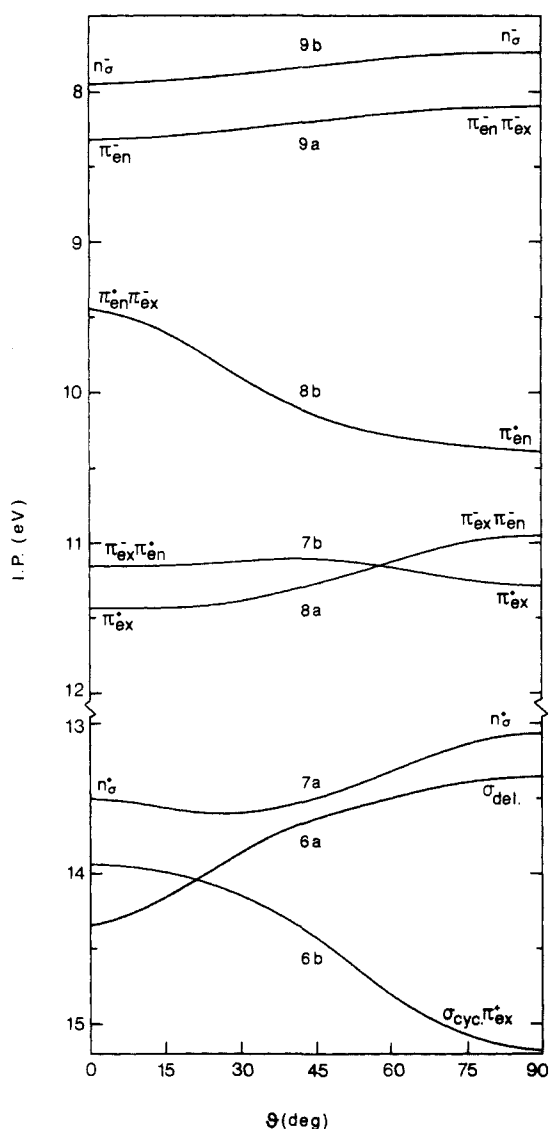
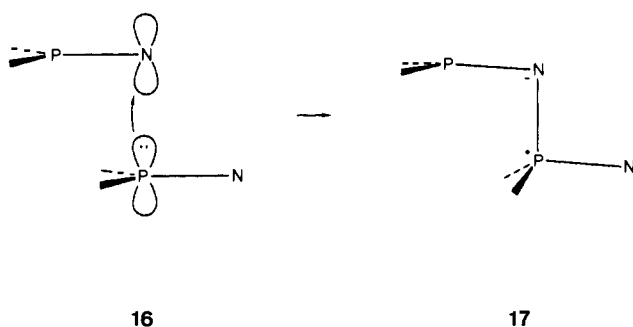

Figure 7. Calculated ionization potentials in 1,1-diaminocyclodiphosphazene.

We will not consider any distorted non-least-motion concerted pathways since obviously there are easier stepwise pathways which pass through a noncyclic zwitterionic intermediate. In the single P-N coupling **16**, giving the open intermediate **17**, the main lone pair repulsion has been cancelled, thus making this reaction easy.



The inner phosphorus and nitrogen atoms in **17** anticipate their nature in the final cycle which is eventually attained after a 180° rotation around N-P⁺ followed by the second P-N coupling. We think that the whole process should require only a weak activation energy, if any. Note the unconstrained character of the intermediate **17**, which should give an important contribution of the entropic term ΔS^\ddagger to the activation free enthalpy ΔG^\ddagger of the whole reaction.

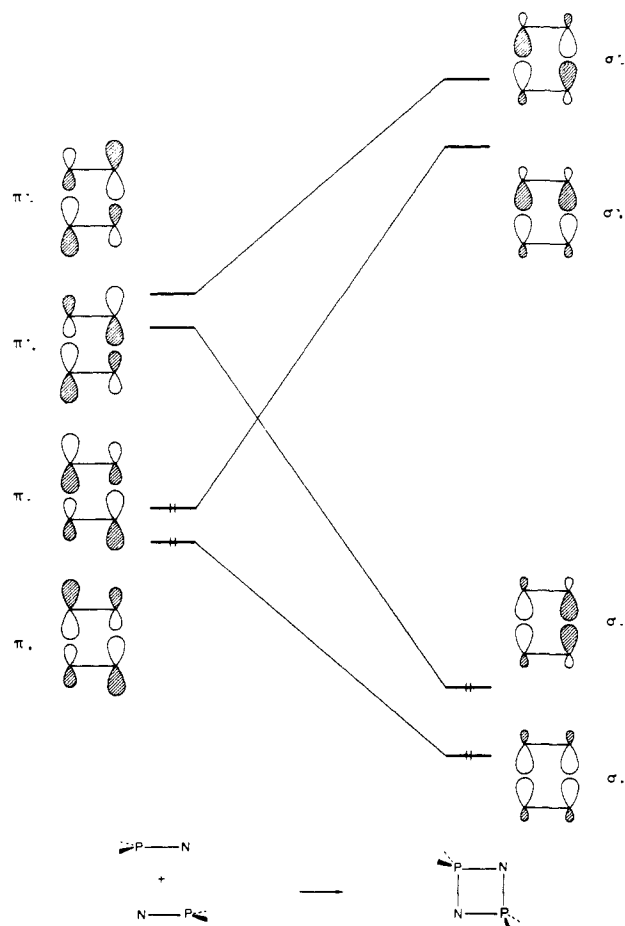
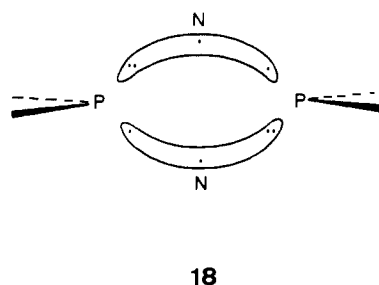

Figure 8. Schematic orbital correlation diagram for the least-motion concerted cyclodimerization of H_2PN . Avoidance is not taken into account.

Figure 8 shows that the concerted cyclodimerization is photochemically allowed, when starting from R_2PN units in a $\pi \rightarrow \pi^*$ (i.e., $n_x(P) \rightarrow \pi_N$) excited state. Since the generation of phosphinitrene is done by photolysis of an azidophosphane,^{6,30} its dimerization may proceed in the excited state. This allowed and easy pathway might explain why the cyclization reaction does not go beyond the formation of the four-membered ring.

VIII. Concluding Remarks

The reactivity of cyclodiphosphazene seems to be dominated by the nucleophilic character of the endocyclic nitrogen atoms.³¹ This, and the trend to ring expansion into cyclotriphosphazene, is in agreement with our theoretical results. Turning to the structural aspect of our four-membered ring, an alternative view of the cycle is to consider two PR_2 groups bound by two three-center four-electron bridge bonds, **18**. In these two electron-rich



(30) Sicard, G.; Baccaredo, A.; Bertrand, G.; Majoral, J. P. *Angew. Chem., Int. Ed. Engl.* **1984**, *23*, 459.

(31) Baccaredo, A.; Bertrand, G.; Majoral, J. P., unpublished results.

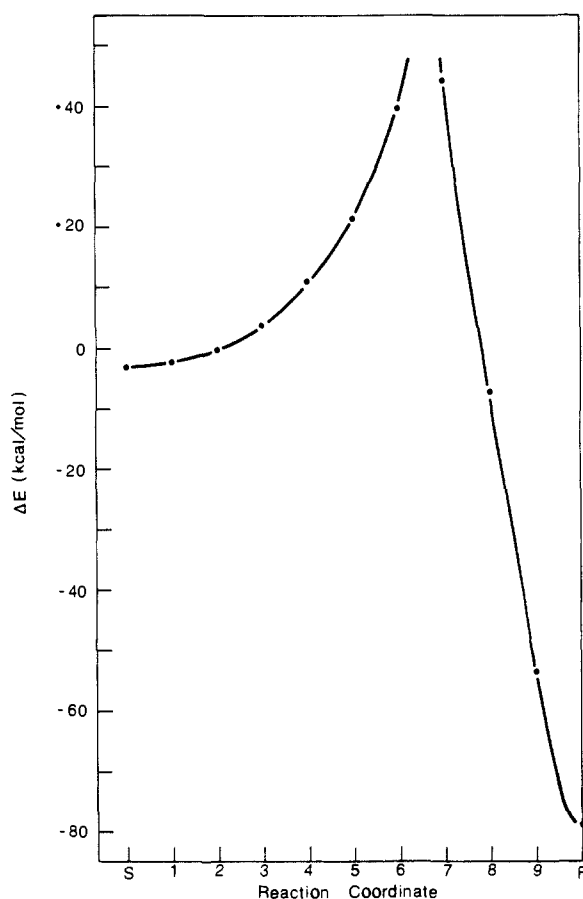

Figure 9. SCF-calculated energy profile for a least-motion concerted cyclodimerization of H_2PN .

bent (or banana) bonds, an excess of electron density is expected on the bridging nitrogens. Another view of the four-membered ring may consider two PR_2^+ groups side bound to a $\text{N}=\text{N}^{2-}$ unit, in the same way that the $\text{Al}^+\text{H}_2^-\text{Al}^+$ valence bond form has been shown to contribute mainly to the bonding in the four-membered ring $[(\text{CH}_3)_2\text{AlH}]_2$.³²

In the field of four-membered rings containing four "active" electrons, the Li_4 and Na_4 alkali tetramers also take up a planar rhombic arrangement with charge alternation.^{33,34} The dissymmetry between the positive and negative centers is more pronounced than in our case ($\alpha = 126^\circ$ in both clusters vs. 95° in $(\text{R}_2\text{PN})_2$).

To date, few organometallic complexes involving endocyclic nitrogens of cyclophosphazenes as polyhapto ligands have been reported.^{35,36} We suggest that a cyclodiphosphazene ring, which could be puckered without too much effort, could be a good candidate for a dihapto complex such as 19. We may suggest $d^6 C_{2v} \text{ML}_4$ as a type of ML_n suitable fragment.

In conclusion, still in organometallic chemistry, we have tried to figure out organometallic analogues for the $(\text{R}_2\text{PN})_2$ ring. Let

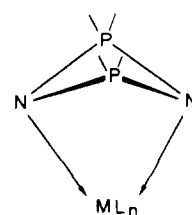

19

us consider first nitrido-bridged dinuclear compounds. The isolobal analogy³⁷ suggests some substitutes for PR_2 :

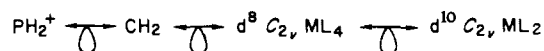

Taking a $d^8 \text{ML}_4$ unit, we can write, for instance, the neutral complex 20. Taking a $d^{10} \text{ML}_2$ unit would give for instance 21. Such compounds are not, to our knowledge, known.³⁸ It is not

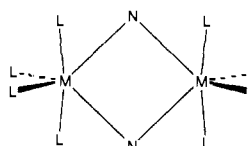

M = Co, Rh, Ir

20

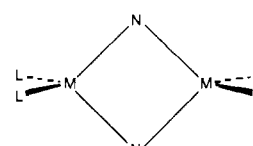

M = Cu, Ag, Au

21

possible to search for a direct analogue of $(\text{R}_2\text{PN})_2$ keeping our PR_2 units, since in organometallic chemistry PR_2 bridging ligands are most commonly phosphido groups PR_2^- , instead of PR_2^+ .³⁹ Many of such binuclear compounds involve ML_2 metallic parts with a d^8 electron count,^{40,41} which displays no close relation to our phosphorus-nitrogen four-membered ring.

Acknowledgment. I express my thanks to Dr. Jean-Pierre Daudey for his decisive assistance throughout this work. This study was suggested by Dr. Guy Bertrand. I thank him and his co-workers for many valuable discussions. I am indebted, for their technical help, to Drs. Antoine Baccaredo (IR data), Jean-Pierre Flament (CI computation), Joël Jaud (X-ray data), and Najia Komiha (pseudopotential gradient routines). I am also grateful to Drs. Jean-Paul Faucher, Jean-Francois Labarre, Jean-Pierre Majoral, Jean-Paul Malrieu, and Michel Pélissier for stimulating discussions. Cooperation from the C.N.U.S.C. computing center (Montpellier) is gratefully acknowledged. Part of the financial support was provided by the GRECO n° 13 0077 "Bas degrés de coordination".

Registry No. $(\text{H}_2\text{PN})_2$, 99708-54-0; $(\text{H}_2\text{PN})_3$, 28921-61-1; $\text{H}_2\text{P}=\text{N}=\text{N}-\text{PH}_2$, 99708-55-1; H_2PN , 25756-69-8.

(32) Pelissier, M.; Malrieu, J. P.; Serafini, A.; Labarre, J. F. *Theoret. Chim. Acta* **1980**, *56*, 175.

(33) (a) Beckmann, H. O.; Koutecký, J.; Bostchwin, P.; Meyer, W. *Chem. Phys. Lett.* **1979**, *67*, 119. (b) Beckmann, H. O.; Koutecký, J.; Bonačič-Koutecký, V. *J. Chem. Phys.* **1980**, *73*, 5182.

(34) Maynau, D.; Malrieu, J. P., unpublished results.

(35) See for instance: Allcock, H. R.; Allen, R. W.; O'Brien, J. P. *J. Am. Chem. Soc.* **1977**, *99*, 3984. Allen, R. W.; O'Brien, J. P.; Allcock, H. R. *J. Am. Chem. Soc.* **1977**, *99*, 3987.

(36) For other metallophosphazenes, see for instance ref 2d,f,g and: Allcock, H. R.; Suszko, P. R.; Wagner, L. J.; Whittle, R. R.; Boso, B. *Organometallics* **1985**, *4*, 446.

(37) Hoffmann, R. *Angew. Chem., Int. Ed. Engl.* **1982**, *21*, 711.

(38) For nitrido-bridged complexes, see: Dehnicke, K.; Strahle, J. *Angew. Chem., Int. Ed. Engl.* **1980**, *20*, 413.

(39) For MO analyses of $(\text{ML}_n-\text{PR}_2)_2$ four-membered ring systems, see: Shaik, S.; Hoffmann, R.; Fisel, C. R.; Summerville, R. H. *J. Am. Chem. Soc.* **1980**, *102*, 4555.

(40) Summerville, R. H.; Hoffmann, R. *J. Am. Chem. Soc.* **1976**, *98*, 7240.

(41) For recent examples, see: (a) Burkhard, E. W.; Mercer, W. C.; Geoffroy, G. L. *Inorg. Chem.* **1984**, *23*, 1779. (b) Gaudiello, J. G.; Wright, T. C.; Jones, R. A.; Bard, A. J. *J. Am. Chem. Soc.* **1985**, *107*, 888.